

END ELEVATION

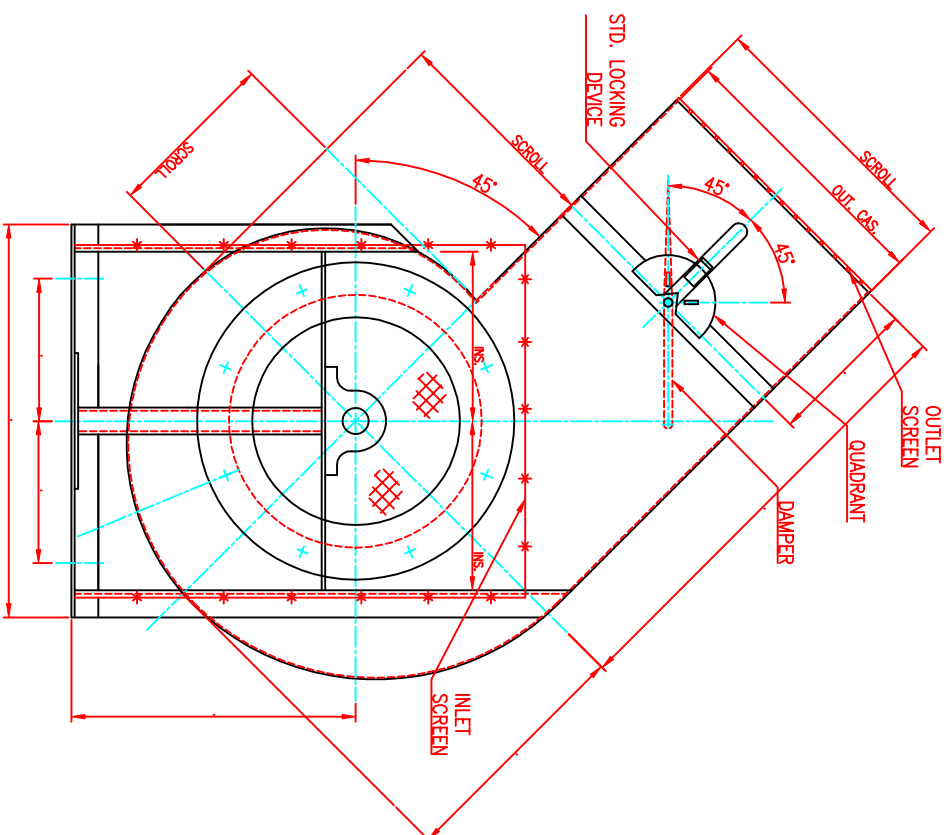

INLET SIDE ELEVATION

POSITION OF DISCHARGE & ROTATION FROM DRIVE SIDE			
BH	CW	BAU	CW
FIG.1	FIG.2	FIG.3	FIG.4
TH	CW	BH	BAU
FIG.5	FIG.6	FIG.8	FIG.11
UB	TAU	TH	TAU
CCW	CCW	CCW	CCW
FIG.12	FIG.13	FIG.14	FIG.15



**SHELDONS ENGINEERING**  
[www.sheldonsengineering.com](http://www.sheldonsengineering.com)  
[sales@sheldonsengineering.com](mailto:sales@sheldonsengineering.com)

TITLE:	PRELIMINARY DRAWING ARR.3 POWER ABSORPTION FAN
DATE:	NOV/2001
DRW. S.P.	CUST.
CHECK	
SCALE:	N.T.S.
	DWG NO.